

# FKS NEWSLETTER

Franke Kitchen Systems - Luxury Products Group  
June 2010

In This Issue:

Franke Product Availability Report  
Expansion of Franke Filtration  
POU Faucets  
Discontinued Product  
AB1953 Update  
Update on Grid Transition  
What's New in Fireclay  
Franke Literature Update  
and more...

Marketing / News

## Authorized Reseller Agreement Update

by Charles Lawrence, General Manager  
Luxury Products Group, FKS

If you are receiving this new Franke newsletter it means you have chosen to partner with us by signing our **Authorized Reseller Agreement**. We are very excited about this ground breaking program in our industry and how it will help you profitably grow in a changing and increasingly complicated market. Franke is committed to the long term growth of our business and we are convinced that the only way to accomplish this is with an equally committed and focused network of resellers.

As of this writing we have a total of 630 authorized resellers with 762 authorized locations on the frankeksd.com dealer locator. This is not complete but we expect it to be fully updated with only authorized locations by June 1. Our plan is to periodically introduce upgrades and enhancements to the program to support the selective Franke network that you are part of. A few recent initiatives that benefit you are:

1. The creation of an encrypted logo available to only authorized websites that decreases the opportunity for copying and pasting the authorized logo.
2. A recent notification was sent to over two dozen unauthorized websites requiring them to remove Franke from their website.

We are very pleased that you have chosen to support our program and we are confident you will benefit from our commitment to you. Many of you have chosen to increase your Franke displays, eliminate competitors and have participated in training programs which suggests you support our efforts...thank you!

We believe the **Reseller Agreement** combined with our industry leading **MAP policy** provides an unmatched program for us to work together. The goal of these programs and all the other activities outlined in the newsletter are for authorized partners only. This focus allows us to better serve you and we hope encourages you to be more supportive of Franke.

## Franke Sponsors Grand Opening Event



Franke Kitchen Systems co-sponsored the "Grande" opening of Grande Central showroom on 56th Street on April 1, 2010. Industry expert and design trend analyst Ellen Cheever was the guest speaker. The event attracted over 700 designers, architects and existing customers.

The new two-story, 4,000-sq.-ft. Grande Central showroom on 56th Street in Manhattan, in the heart of the design district, is intended to be different from the typical plumbing wholesaler's showroom. Upon entering and before reaching the reception desk, the visitor encounters "Sierra Cascades," an original collectible print of waterfalls in California signed by photographer Peter Lik. It measures 80 inches by 27 inches vertically,

Various Franke products are displayed in the showroom. Two Franke sinks that are featured are Franke's Culinary Work Center, CWX161-W and Fireclay Apron Front sink, FHK710-33WH.

The showroom is designed to "blur the lines between high-end artistic kitchen and bath products and other art," according to Howard Frankel, President. Grande Central Showroom has four locations in Yonkers, New York, 3,000 sq. ft.; Park Avenue, Manhattan, 750 sq. ft.; Bond Street, Manhattan, 3,000 sq. ft.; 56th Street, Manhattan, 4,000 sq. ft. All but one of the showrooms are open for some time on Saturdays in addition to regular weekday hours and some have evening hours once a week.

The midtown showroom also has a flat-screen monitor with recent movies to entertain children while their parents shop. Source info: supplyht.com



## Keeping Stats on Frankeksd.com

**Frankeksd.com web visits up 30% in April 2010 compared to last year!**

Below is a list of some of the top referral sites bringing traffic to [frankeksd.com](http://frankeksd.com). THANK YOU to all of our Franke supporters and your online efforts!

Franke.com  
Frankeconsumerproducts.com  
Ferguson.com  
Frankekitchensinks.com  
Albertleeappliance.com  
Europeansinkoutlet.com  
Keidel.com  
Faucetdepot.com  
Purcellmurray.com  
Standardssofexcellence.com  
Thisoldhouse.com

39% of frankeksd.com visitors come back multiple times!

Top Search engines bringing traffic to [frankeksd.com](http://frankeksd.com)

- |           |          |
|-----------|----------|
| 1. Google | 3. Yahoo |
| 2. Bing   | 4. AOL   |

Top 10 Pages (by title) Visited in April 2010

1. Sinks
2. Products
3. Undermount Sinks
4. Faucets
5. Accessories
6. Online Store
7. Dealer Locator
8. Topmount Sinks
9. Pull-out Faucets
10. Water Filtration

## Franke Product Availability Report

If you have recently logged into the frankeksd.com site, you may have noticed a new tool – our Product Availability feature.

We are pleased to introduce this new product availability data to improve communication.

This report is available on a 24 HOUR basis and is updated every half hour from 7am to 8pm, EST.

This feature facilitates the ordering and quoting process and will also help reduce call volume to our Customer Service department, so they can better serve your needs when you do need to call.

With this report you can also check the status of the inventory, whether the item will be phased out or is currently active.

All information is confidential and authorized only to customers who have a frankeksd.com login.

Future enhancements to the report are coming soon!



## Franke Authorized Wholesalers List Now Available

You can now find a list of Franke Authorized Wholesalers on the login site of Frankeksd.com. The listing can be found under the 'Company' heading.

The file is currently in pdf format with locations sorted by state. As the list continues to grow, the format will be updated for easier viewing. Please be patient as we work to update the list on a regular basis.

If you see an incorrect location, please send an email to [ks-marketing@franke.com](mailto:ks-marketing@franke.com) to make the changes.

## Franke Kitchen Systems Launches a Facebook Page



As social media networking is coming the forefront, even in the luxury market, you can now find Franke Kitchen Systems on Facebook. See Franke's Facebook page for new Press Releases, product updates, or even start a discussion on Franke products! If you have your own Facebook page, become a [Fan of Franke](#).

Franke's Twitter page is gaining more popularity with 193 followers and growing in numbers every day. You can now find Facebook and Twitter thumbnails throughout the frankeksd.com website. Direct your customers here for Franke updates!

### Product Updates

## Update on Grid Transition

### Rolling change to all stainless grids

Finally the transition from coated grids to uncoated stainless steel grids is beginning. As communicated throughout, this will happen in Phases. For the most part the phases will be based on demand.

The changes that you will see are: clear bumpers that won't scuff or scratch. The bumper is a replaceable part, just like the current grid "feet" covers, and the material is FDA approved, since the grids are considered to come into contact with food. Additionally, the designs will become consistent and the gauge will be representative of nothing but a luxury product at 4.99mm gauge!

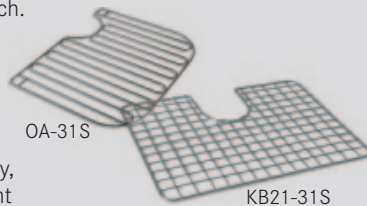

The current schedule has the first order being manufactured. This order includes the OC-31S-RH, OC-31S-LH, PR-31S, VN-31S, KB21-31S. Therefore the coated counter-part will soon be discontinued. This is a complete eventual transition away from coated grids.

Up and coming in the next phase are the grids that accompany the new PSX11021, PSX1102710, PSX1103010, PSX120309 and PSX120339, and Manor House sinks. Corresponding bottom grids to the Phase I shelf grids will be Phase III and the most recent fireclay introductions (KBK and FHK) grids will follow. We will continue to define the grids as we move through existing inventory and demand grows. Each of the phases listed and all additional to come will be continuous until the transition is complete.

## What's New in Fireclay

### MHK110-28

Back by popular demand!

Ideal for adding charm to smaller urban kitchens, this deep and roomy model is glazed on three sides in order to undermount as desired. This exclusive Fireclay sink is created especially for Franke by the world-renowned firm of Villeroy & Boch. With a finish that is extremely hard and scratch-proof, this sink has an ultra-smooth and dirt repellent surface that will remain beautiful for years.



Shown with FHPD500 faucet.

**Available in 2 colors:**  
White and Biscuit

Launch details:

- order has been placed
- awaiting manufacturing and shipping schedule from V&B

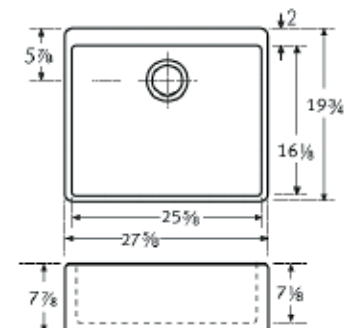

## Intro to the Expansion of Franke Filtration COMING SOON: The Expansion of Franke Filtration

Mid June 2010 we will introduce the **NEW FRX01**.

Not all consumers looking for a filter have the need or concern to have to address heavy metals and lead. Quite simply, they just have the need to **remove a bad smell or taste** in the water. This being the case, they will be able to purchase a more cost effective option in the **FRX01** filter from Franke.



We will bring more details to you when we launch the filter so that you can provide your customers with the knowledge and differentiation of the Franke Replacement Filter options.

## Discontinued Product in Upcoming Catalog

DISCONTINUED WHEN OUT-OF-STOCK

Franke is Phasing Out the following products. When we introduce our new catalog, the following items will not be included:

- ARX621 (RH & LH)
- CPX620
- EIX620



## New Point of Use Faucets

**FINALLY refreshed designs of our current DW and LB products** are going to be coming your way. We are anticipating an August launch. Because these are technically new products, there will be new part numbers. They will be similar, so that you don't have to relearn the nomenclature, but new part numbers are required to avoid any confusion in the products.

Late this year you can expect new **contemporary and traditional designs**.

It's been a long time coming, but we are confident that these new POU faucets are going to increase your sales in this evergrowing category . . . stay tuned.



## DWO Faucet Reminder

The most current listing of DWO faucets was communicated to you via a Marketing Bulletin on May 19, 2010. To reference the bulletin, please logon to the distributor site and click on 'Marketing'.

As previously communicated, our goal is to continue to invest wisely in exciting new products that are just beginning their life cycle, and use our resources toward developing future successful models. While this may seem like a large number of skus, the volume of these models has declined significantly over the years.

We are excited about the new products in development and look forward to introducing them to you in the upcoming months!

## AB 1953 Update

The California Assembly Bill 1953 and Vermont Lead-Free Law S152, which prohibit the sale of plumbing fixtures whose wetted surfaces contain more than a weighted average of 0.25% lead have been in effect since January 1, 2010. The term "plumbing fixtures" is defined as pipes, pipe, plumbing fittings and fixtures used to convey or dispense water for human consumption.

In December 2008, NSF/ANSI Standard 61 was revised to add requirements to the standard allowing manufacturers the option of being certified to a lead content standard in jurisdictions with a 0.25% weighted average lead content requirement.

(For more information on Annex G, go to <http://www.nsf.org/>)

As of this time, the following Franke faucets are certified but not yet AB1953 compliant, and will not become available in AB1953 compliant brass until the end of 2010:

- FF5000 and FF5080
- FF1700 and FF1780
- FF1900 and FF1980

The FFPD100 and FFPD180 will not be manufactured in AB 1953 compliant material in the foreseeable future.

The following faucets will be both certified and compliant with the next shipment arriving in Ruston this summer (exact date to be announced):

- FFP1000 and FFP1080
- FFP1100 and FFP1180
- FF1800 and FF1880
- FF2000 and FF2080
- FFPS700 and FFPS780

All other Franke kitchen faucets are already available in lead-free brass.



## 2010 Franke Literature New Catalog Format Coming in early July

The Marketing team is excited to be bringing you a new layout for the upcoming Franke catalog. Everything you love about the old format will be combined with new, very useful information as well as new photography!

### NEW SECTIONS:

- Why Franke section - stainless steel product knowledge
- Category header pages: Photo at top of page, product selling points on bottom
- Cutting board F&B page defining Iroko wood
- Grid F&B page defining the specifications of our grids
- Filtration section detailing the filter options, what each filters, and product knowledge selling points of the benefits of POU filtration



Show with KBX12034 sink, FF-1600 Faucet and KB-3000R Grid Mat

### STAINLESS STEEL DOUBLE BOWL UNDERMOUNTS

Ut enim deserit amet, consetetur adipisicing elit. In id massa nulla, vitae hendrerit purus. Viverra vestibulum magna ut justo agnate velipsum. Aliquam ut amet nisi eros. Vivamus acelerisque sodales massa, a dictum erat, tempus quis. Donec congue nulla sit nibh vehicula et pharetra libero consetetur. Proin tristique turpis, consetetur congue, cursus vel justo. Etiam eget peras ac lacus tuncet phasellus. Id et fructu. Aliquam erat volutpat. In libero ac nisi auctor vel lacinia ante congue. Proin lobortis conmodo imperdiet. In nisi ante, feugiat sit lacinia vehicula, conmodo ac purus. Sed tristique, ipsum quis velipsum sagittis, nibh ligula lobortis velus, vel cursus purus sed nulla.

**KBX 12030** NEW **FPO** **KUBUS**

Interior Dimensions: 28 1/2" x 15 1/2" x 7 3/4"  
Exterior Dimensions: 30 1/2" x 17 1/2" x 7 3/4"  
Minimum Cabinet Size: 32"

Custom Accessories: **Basin Grid** (KB-100), **Roller Mat** (KB-200), **Cutting Board** (KB-300), **Colander** (KB-400)

---

**KBX 12034** **KUBUS**

Interior Dimensions: 33 1/2" x 15 1/2" x 7 3/4"  
Exterior Dimensions: 35 1/2" x 17 1/2" x 7 3/4"  
Minimum Cabinet Size: 34"

Custom Accessories: **Basin Grid** (KB-100), **Roller Mat** (KB-200), **Cutting Board** (KB-300), **Colander** (KB-400)

---

**KBX 12039** **KUBUS**

Interior Dimensions: 28 1/2" x 15 1/2" x 7 3/4"  
Exterior Dimensions: 30 1/2" x 17 1/2" x 7 3/4"  
Minimum Cabinet Size: 42"

Custom Accessories: **Basin Grid** (KB-100), **Roller Mat** (KB-200), **Cutting Board** (KB-300), **Colander** (KB-400)

---

**KBX 12043** **KUBUS**

Interior Dimensions: 40 1/2" x 15 1/2" x 7 3/4"  
Exterior Dimensions: 42 1/2" x 17 1/2" x 7 3/4"  
Minimum Cabinet Size: 48"

Custom Accessories: **Basin Grid** (KB-100), **Roller Mat** (KB-200), **Cutting Board** (KB-300), **Colander** (KB-400)

## Franke in the News

### PRESS RELEASES

#### May 2010

Franke Finds Ways to Offer the Luxury of "Both / And"

#### April 2010

Franke Creates First and Only "Partner Loyalty Program"

Press Release 'picked up' by:

- Bath & Kitchen Pro Online
- Supply House Times Online
- Kitchen & Bath Business Online
- The Wholesaler Magazine
- Kitchen & Bath Design News

#### March 2010

Franke Liberates the "Inner Chef" with a Dream Team...

### MEDIA PLACEMENTS

#### July 2010

Remodeling, Replacement Contractor, Upscale Remodeling - Rail System  
Kitchen & Bath Design News - Oceania  
Fireclay, or ManorHouse Sink

#### June 2010

Kitchen & Bath Design News - CWX-161W, FF1700, BBX160 or Beach Range Hood

#### April 2010

BHG.com - ORK110

#### Spring / Summer

K&B Ideas: Products Guide - FHK710-30  
Distinctive Kitchen Solutions - Oceania Sink, FFPS200, FFPD100

## "THANK YOU" to franke.com Login Users

By: Krista Rivers

There has been a noticeable interest in the franke.com login site since its first launch. As of late, many of you are utilizing this information on a regular basis. This creates less calls to the Franke Customer Service department as well as an added convenience for the user!

Login information was just recently issued to a new user, who commented, "There is a wealth of information on that site." I encourage those of you who haven't visited the site frequently, to put it to good use! You can always find the most up-to-date Franke product information and pricing on this site.

A special thanks to Ellsworth, Trevarrow, Kimball Distributing, Boston Basins and Bradlee Distributors to being our top users for 2010.

## Analysis for the Housing Market

Hanley Wood Market Intelligence

By: Ken Lee

New home sales in March jumped to its fastest annual pace since July 2009. After dropping for four consecutive months, new home sales rebounded 26.9% from the previous month to a seasonally-adjusted annual rate of 411,000 units. The monthly increase in March is the largest since 1963.

The annual sales pace of new homes is coming off an all-time low set last month in February. New home sales for the previous three months were revised higher by 47,000 units. New home sales are up 23.8% from the 332,000 units in March 2009 but are 19.3% lower than the March 2008 figure of 509,000.

## Send Us Your Story

We would like to share in your success stories!

Have you had a recent project that was executed exactly as planned, or even better than planned? Have you recently hosted or attended a trade show or event where you found out more interesting facts about Franke products? We want to hear from you! Please submit your story to [ks-marketing-services.us@franke.com](mailto:ks-marketing-services.us@franke.com) to be considered for the July 2010 issue.